

# MODE LAVABO ME070DBI

CE EN 14688:2015

# GLOBO



Effetto antibatterico su ceramica BATAFORM®



Prodotto smaltato con CERASLIDE®

Cod. **ME070DBI**

Lavabo 70,45 h 18,5 cm destro. Installazione sospesa. Completo di fissaggi. Peso 16 Kg.

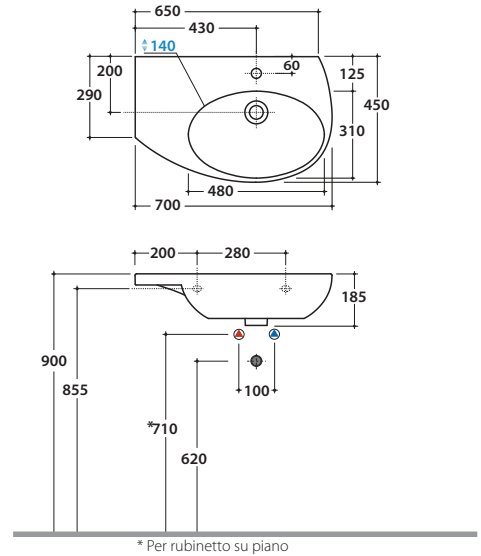

Cod. **FI012BI**

Piletta up and down con tappo in ceramica per lavabi con troppo pieno. Peso 0,5 Kg



Cod. **FI012CR**

Piletta cromata up and down per lavabi con troppopieno. Peso 0,5 Kg

## MODE PORTASCIUGAMANI LATERALE ME002YAR PER LAVABI ME070D ME070S

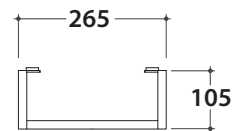
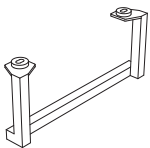

Finiture



Acciaio nero opaco

Cod. **ME002YAR**

Portasciugamani laterale nero opaco 26,5x11 cm. Per lavabi ME070SBI e ME070DBI. Peso 3 Kg.